



Datasheet

IMPINJ R700 RAIN RFID READER

DATASHEET

OVERVIEW

The Impinj R700 reader is designed to support enterprise RAIN deployments that need industry-leading performance, enterprise-grade reliability and security, and support for next-gen RAIN tags. IoT developers can easily build and deploy customized solutions with developer-friendly tools, increased processing power, and increased on-reader memory.

This document constitutes the electrical and mechanical specifications pertaining to the Impinj R700 RAIN RFID reader. It contains a functional overview, mechanical characteristics, and electrical specifications. For technical support, visit the Impinj Support Portal at support.impinj.com.

Table 1: Impinj R700 Key Specifications

Specification	Description
Physical Dimensions	With mounting brackets 8.4 in. long x 7.4 in. wide x 1.2 in. deep (21.5 cm x 18.7 cm x 3.0 cm) Without brackets: 8.4 in. width x 5.9 in. depth x 1.2 in. height inch (21.4 x 14.9 x 3.0 cm)
Power Supply	PoE (802.3af), PoE+ (802.3at) with LLDP for power negotiation
Air Interface Protocol	EPCglobal UHF Gen2 v2 / ISO 18000-63 RFID
Antenna Ports	4, Monostatic (RP-TNC)
Frequency Range	IPJ-R700-241 ETSI Reader 865 – 868 MHz, 915 – 921 MHz IPJ-R700-341 Global Reader: 902 – 928 MHz IPJ-R700-441 Japan Reader 916.7 to 920.9 MHz
Transmit Power	PoE+: 33 dBm max PoE: 30 dBm max
Receive Sensitivity	-92 dBm max
Processor	Dual-Core 1 GHz ARM processor
Memory	1 GB Flash, 1 GB RAM
Network Connectivity	10/100/1000 BASE-T Ethernet
Device Connectivity	3 USB Type-A, 1 micro USB
General Purpose I/O	3 out, 2 in

Figure 1: Impinj R700 Top View



Figure 2: Impinj R700 Bottom View



Figure 3: Impinj R700 Front View



Figure 4: Impinj R700 Back View



Figure 5: Impinj R700 Left View



Figure 6: Impinj R700 Right View

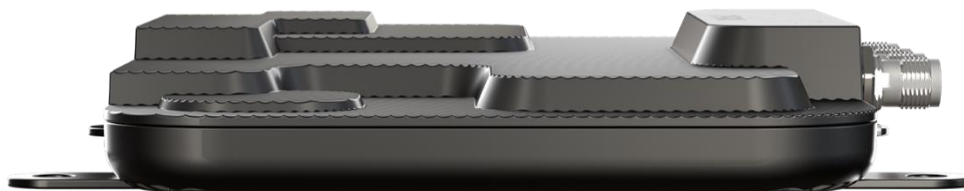

TABLE OF CONTENTS

1	Introduction	5
1.1	Features & Benefits	5
1.2	Block Diagram	5
2	Specifications	6
2.1	Mechanical	6
2.2	Environmental	6
2.3	RFID	7
2.3.1	Transmit Power	7
2.3.2	Gen 2 Reader Modes	7
2.3.3	Read Rate	7
2.3.4	Receive Sensitivity	8
2.4	Connectivity	8
2.4.1	Power	8
2.4.2	GPIO	9
2.5	Operating System	10
3	Development Libraries	10
4	Regulatory Specifications	11
5	Ordering Information	11
5.1	Reader	11
5.2	Accessories and Warranties	12
5.3	Antennas and Antenna Cables	13
6	Impinj Fixed Reader Comparison	15
7	Additional User Documentation	16
8	Change Log	16
8.1	June 2020	16
8.2	October 2020	16
8.3	February 2021	16
8.4	July 2021	17
9	Notices	18

1 INTRODUCTION

The Impinj R700 RAIN RFID reader is a four-port RFID reader compliant with the GS1 UHF Gen2v2 protocol which ISO/IEC standardizes as 18000-63. Impinj R700 is specifically designed to meet the increasing demands of next-generation IoT solutions and enterprise-grade RAIN deployments.

1.1 Features & Benefits

- **Industry-leading sensitivity:** Empowers reading tags farther and faster, and future proofing of IoT solutions
- **Powerful edge processing:** Enables intelligent on-reader RAIN RFID tag-processing algorithms
- **Secure, upgradable Linux OS:** Delivers enterprise-grade security and reliability, and the flexibility to customize with on-reader applications
- **Simple IoT device interface:** Easily connects IoT applications to configure and control devices, and to consume RAIN data with native support for MQTT
- **Optimized design for inventory:** Increases read rate and improves read zone control at lower transmit power
- **Rich peripheral and accessory support:** Provides versatility with support for USB flash drives, Wi-Fi adapters, and up to 32 antennas via optional antenna hub

1.2 Block Diagram

Figure 7: Impinj R700 Block Diagram

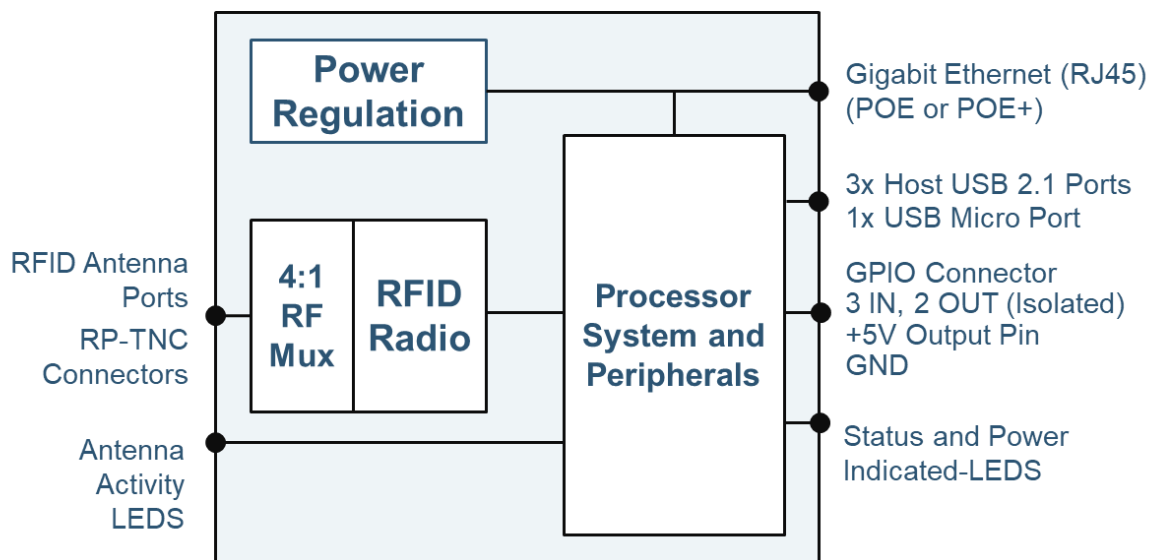

2 SPECIFICATIONS

2.1 Mechanical

Table 2: Impinj R700 Mechanical Specifications

Specification	Description
Physical Dimensions	With mounting brackets 8.4 in. long x 7.4 in. wide x 1.2 in. deep (21.5 cm x 18.7 cm x 3.0 cm) Without brackets: 8.4 in. width x 5.9 in. depth x 1.2 in. height inch (21.4 x 14.9 x 3.0 cm)
Mounting	VESA 100 x100 mm on bottom of the enclosure Two removable brackets compatible with Impinj Speedway mounting system
Weight	2.12 lb., 0.96 kg
Housing Material	Die-cast Aluminum
Factory Reset Button	Restores reader to known factory state
LED Indicators	System status, inventory, firmware upgrade, antenna activity, network activity

2.2 Environmental

Table 3: Impinj R700 Environmental Specifications

Specification	Description
Operating Temperature	-4° F to 122° F (-20° C to 50° C)
Storage Temperature	-4° F to 158° F (-20° C to 70° C)
Humidity	5% - 95% non-condensing
Sealing	Ingress Protection (IP) 50 rating
Shock and Vibration	United States Military Standard MIL-STD-810G

2.3 RFID

Table 4: Impinj R700 RFID Specifications

Specification	Description
Air Protocol	EPCglobal UHF Class 1 Gen 2 / ISO 18000-63 RFID
Transmit Power	10 – 30 dBm (PoE All Models, Japan) 10 – 31.5 dBm (PoE+, ETSI Lower Band) 10 – 33 dBm (PoE+, FCC / ETSI Upper Band)
Transmit Power Resolution	0.25 dB
Transmit Power Accuracy	+/- 0.5 dB
Frequency Range	IPJ-R700-341 Global Reader: 902 – 928 MHz IPJ-R700-241 ETSI Reader 865 – 868 MHz, 915 – 921 MHz IPJ-R700-441 Japan Reader 916.7 to 920.9 MHz
Return Loss	10 dB min
Read Rate	Up to 1100 reads per second
Antenna Impedance	50 ohms
Max Receive Sensitivity	-92 dBm at 10-3-bit error rate, Dense Reader M8 reader mode
Gen 2 Reader Modes	Static and Dynamic RF Modes various per region

2.3.1 Transmit Power

The user configures Impinj R700 transmit power, the conducted power available at the RF port on the reader. For all Impinj R700 reader models, the reader will limit the maximum transmit power to 30 dBm while configured to use PoE power. When configured to use PoE+ power, the reader may allow for a higher maximum transmit if the region allows for it. The Impinj R700 will only present valid output powers for the region it is configured to operate in. For additional information on how to properly set transmit power to comply with regulatory rules, refer to the Impinj R700 Installation and Operations Guide. For additional information on the differences between PoE and PoE+ power refer to section 2.4.1 of this datasheet.

2.3.2 Gen 2 Reader Modes

The Impinj R700 includes support for two types of reader modes: static and dynamic. The number of modes varies per region and comply with regulatory agencies. For additional detail on Reader Modes visit the Impinj Support Portal.

2.3.3 Read Rate

The Impinj R700 read rate varies depending on the reader configuration and number of tags in the field of view. The maximum read rate can only be achieved while using reader mode 0 in an FCC-like region.

2.3.4 Receive Sensitivity

The receive sensitivity of the Impinj R700 varies depending on the RF mode chosen to perform Inventory. Applications that require the lowest (i.e. best) receive sensitivity should choose Dense Reader M8 mode. To learn more about reader modes and receive sensitivity, visit the Impinj Support Portal.

2.4 Connectivity

Table 5: Impinj R700 Connectivity Specifications

Specification	Description
Network	10/100/1000 Base-T Ethernet (RJ45)
Antenna Ports	4 monostatic ports (RP-TNC)
USB	3 Type A host, 1 micro device
Power	PoE (802.3af), PoE+ (802.3at) with LLDP for power negotiation
General Purpose I/O	3 out, 2 in optically isolated
General Purpose I/O Header	Phoenix Contact 9 pin 3.81 mm pitch

2.4.1 Power

The Impinj R700 is powered exclusively through Power over Ethernet (PoE) or PoE+ via the ethernet port. For applications where the reader is not connected to a PoE capable switch, users can apply a midspan injector to add inline power to a network connection via a power supply. By default, the Impinj R700 will attempt to negotiate power using Link Layer Discovery Protocol (LLDP). If the negotiate fails, the Impinj R700 will default to using PoE power.

Impinj recommends PoE+ power when using the Impinj R700 to source power to external USB devices or through the general-purpose outputs.

2.4.2 GPIO

The Impinj R700 utilizes a Phoenix Contact 9 position 3.81 mm pitch header to expose the GPIO signals. To connect external signals, a matching terminal block must be installed. Pin 1 is located nearest the push-pin factory reset button.

Table 6: Impinj R700 GPIO Pin Assignments

Pin	Assignment
1	+5V (500 mA max current)
2	Chassis GND
3	IN 0
4	IN 1
5	OUT 0
6	OUT 1
7	OUT 2
8	V MINUS
9	V PLUS

Figure 8: Impinj R700 GPIO Pin Locations



Table 7: Impinj R700 GPIO Electrical Specifications

Specification	Description
V PLUS	5 – 30 V (reference to V MINUS)
Input Logic 0	0 - 0.8 V
Input Logic 1	3 – 30 V
Output Logic 0	0 – 0.5 V (reference to V MINUS)
Output Logic 1	V PLUS – 0.5 V
GPO Current Draw	1.5 A Source or Sink
Isolation	Optical

2.5 Operating System

Table 8: Impinj R700 Operating System Specifications

Specification	Description
Processor	Dual-Core 1 GHz Cortex A7
Memory	1 GB Flash, 1 GB RAM
Operating System	Linux, 5.4 kernel
Firmware	Impinj R700 Firmware
Firmware Upgrade	Web-based and remote capable
Network Stack	IPv4, IPv6
Network Services	SSH, HTTP, HTTPS, NTP, DHCP, SFTP, mDNS
Network Security	802.1x port security
Network Management	Event logs with syslog forwarding

3 DEVELOPMENT LIBRARIES

Table 9: Impinj R700 Supported Development Libraries

Specification	Description
Reader configuration REST API	OpenAPI compatible RESTful configuration API with support for over 80 languages.
Impinj Octane SDK	Host-based applications (.NET, Java)
Impinj Octane LLRP toolkit	Host-based applications (.NET, Java, C, C++) compatible with LLRP 1.0.1 with Impinj Extensions
Impinj R700 embedded toolkit	Compiler (C, C++) and precompiled Octane LLRP libraries to develop on-reader applications

4 REGULATORY SPECIFICATIONS

Table 10: Impinj R700 Regulatory Specifications

Specification	Description
RF	USA and Canada <ul style="list-style-type: none"> Federal Communications Commission (FCC) Part 15.247 and 15.249 Professional Installation required under FCC rules EU <ul style="list-style-type: none"> EN 302 208 v3.3.1 EN 301 489-3 v2.2.1 EN 300 489-1 v2.2.0 Japan <ul style="list-style-type: none"> ARIB STD-T106
Safety	USA and Canada <ul style="list-style-type: none"> UL listed EU <ul style="list-style-type: none"> CE mark
Hazardous Substances	RoHS3 2015/863 compliant

The latest regional certifications are available on the [Impinj Support Portal](#).

5 ORDERING INFORMATION

5.1 Reader

Table 11: Impinj R700 Part Number Information

Specification	Description
IPJ-R700-241	Impinj R700 RAIN RFID reader, 4-Port, ETSI
IPJ-R700-341	Impinj R700 RAIN RFID reader, 4-Port, FGX
IPJ-R700-441	Impinj R700 RAIN RFID reader, 4-Port, Japan

5.2 Accessories and Warranties

Table 12: Impinj R700 Hardware Accessories and Services

Part Number	Name	Description																												
IPJ-A6010	Impinj R700 antenna hub	The Impinj R700 antenna hub expands the number of antennas that can connect to an Impinj R700 reader by allowing eight antennas to connect to one antenna port for a total of 32 antennas per reader.																												
IPJ-A5100-000	Impinj R700 water-resistant case	IP54 water resistant case																												
IPJ-A2010	PoE+ Midspan Injector	PoE+ midspan power injector (without AC power cord)																												
IPJ-A2041-xxx	AC Power Cord for PoE+ injector	<table border="0"> <tr> <td>ARG</td> <td>Argentina</td> <td>RSA</td> <td>South Africa</td> </tr> <tr> <td>AUS</td> <td>Australia, New Zealand</td> <td>UK1</td> <td>UK, Singapore</td> </tr> <tr> <td>BRA</td> <td>Brazil</td> <td></td> <td>Malaysia,</td> </tr> <tr> <td>CHN</td> <td>China</td> <td></td> <td>Hong Kong</td> </tr> <tr> <td>EU1</td> <td>Europe</td> <td>USA</td> <td>USA</td> </tr> <tr> <td>IND</td> <td>India</td> <td></td> <td></td> </tr> <tr> <td>JPN</td> <td>Japan</td> <td></td> <td></td> </tr> </table>	ARG	Argentina	RSA	South Africa	AUS	Australia, New Zealand	UK1	UK, Singapore	BRA	Brazil		Malaysia,	CHN	China		Hong Kong	EU1	Europe	USA	USA	IND	India			JPN	Japan		
ARG	Argentina	RSA	South Africa																											
AUS	Australia, New Zealand	UK1	UK, Singapore																											
BRA	Brazil		Malaysia,																											
CHN	China		Hong Kong																											
EU1	Europe	USA	USA																											
IND	India																													
JPN	Japan																													
IPJ-C205x	Warranty extension	<table border="0"> <tr> <td>1</td> <td>1-year</td> </tr> <tr> <td>2</td> <td>2-year</td> </tr> <tr> <td>3</td> <td>3-year</td> </tr> </table>	1	1-year	2	2-year	3	3-year																						
1	1-year																													
2	2-year																													
3	3-year																													
IPJ-C2001	Firmware Updates	Firmware Updates (1-year)																												

5.3 Antennas and Antenna Cables

Table 13: Antenna and Antenna Cable Ordering Information

Part Number	Part Name	Description
IPJ-A0303-000	Impinj Mini-Guardrail antenna	Impinj Mini-Guardrail antennas are ideal for fixed spaces that need exceptional control in a small zone. The antenna is unobtrusive and optimal for monitoring items within cabinets or other small enclosures. Provides broadband support for optimal performance globally.
IPJ-A0311-xxx	Impinj Threshold antenna EU1 ETSI USA FCC	Impinj Threshold antennas identify items as they pass over or under a threshold or boundary. The antenna's high-capacity read range is designed to maximize intensity in highly specific zones providing wide zone coverage ideal for a road race course or other boundary or threshold crossing. Provides optimized performance in FCC- and ETSI-supported regions.
IPJ-A0400-xxx	CSL Brickyard Antenna EU1 ETSI USA FCC	Brickyard antennas by CSL are ideal for fixed spaces that need exceptional control in a small zone. These antennas are unobtrusive and are optimal for tracking items on tables, point of sale terminals, or within cabinets.
IPJ-A0402-xxx	Impinj Guardwall Antenna EU1 ETSI USA FCC	Deployed in pairs, Impinj Guardwall antennas provide a tightly controlled read zone to monitor items, packages, or cases moving on conveyor systems. Provides optimized performance in FCC- and ETSI-supported regions.
IPJ-A0404-000	Impinj Matchbox Antenna	The Impinj MatchBox antenna is ideal for tight-proximity spaces that need exceptional control in a small zone. The antenna is unobtrusive and can monitor items within cabinets or other small enclosures. Provides bi-directional, short-range coverage and broadband support for optimal performance globally.
IPJ-A1000-xxx	Laird Far-Field LHP antenna EU1 ETSI USA FCC	Far-Field antennas by Laird provide highly efficient coverage with a weather-resistant design. These antennas have maximum performance at distances over 5 feet and are ideal for situations where the tagged item will be at different angles and heights. Left hand circularly polarized (LHP) version.
IPJ-A1001-xxx	Laird Far-Field RHP antenna EU1 ETSI USA FCC	Far-Field antennas by Laird provide highly efficient coverage with a weather-resistant design. These antennas have maximum performance at distances over 5 feet and are ideal for situations where the tagged item will be at different angles and heights. Right hand circularly polarized (RHP) version.

IPJ-A1100-xxx	Times-7 Slim Outdoor antenna EU1 ETSI USA FCC	Slim Outdoor antennas by Times-7 provide maximum zone coverage in a low-profile design for both indoor and outdoor use. These rugged antennas have optimal read performance in a broad range of environments over long read ranges up to 29 feet.
IPJ-A1200-xxx	Times-7 Compact Outdoor antenna EU1 ETSI USA FCC	Compact Outdoor antennas by Times-7 provide read zone coverage in a compact design for both indoor and outdoor use. These compact antennas have an aesthetically pleasing design and provide optimal performance in a broad range of environments over long read ranges up to 19 feet. Provides optimized performance in FCC- and ETSI-supported regions
IPJ-A300x-000	Antenna Cable 2 2 meters 4 4 meters 8 8 meters	RG58, SMA male to R-TNC male
IPJ-A311x-000	Antenna Cable 2 2.1 meters 4 4.6 meters	Low Loss/High Flex, SMA male to R-TNC male
IPJ-A312x-000	Antenna Cable 2 2.1 meters 4 4.6 meters	Low Loss/High Flex, SMA male to SMA male

6 IMPINJ FIXED READER COMPARISON

Table 14: Impinj Fixed Reader Comparison

Feature	Impinj R700	Impinj R420	Impinj R220	Impinj R120*
Antenna Ports	4	4	2	1
Read Zones (max)	32	32	16	8
Read Rate (max per-second)	1100	1100	200	200
Transmit Power (max, dBm)	33.0	32.5	32.5	30
Receive Sensitivity (max, dBm)	-92	-84	-84	-84
Processor Speed	1 GHz (dual core)	400 MHz (single core)	400 MHz (single core)	400 MHz (single core)
Random Access Memory (MB)	1024	256	256	256
Custom Application Partition (MB)	128	32	32	32
Impinj IoT device interface	yes	no	no	no
USB Peripheral Slots	3	1	1	1
GPIO Connector	Integrated	Accessory	Accessory	Accessory
Ethernet Network Speed	10/100/1000	10/100	10/100	10/100
Power Over Ethernet Support	PoE PoE+	PoE PoE+ EU2 model	PoE	PoE

*The Impinj R120 is currently undergoing the End-of-Life process and is not recommended for new designs.

7 ADDITIONAL USER DOCUMENTATION

The following table lists documents that may be helpful in operating the Impinj R700. These documents can be found on the Impinj Support Portal at [Impinj R700 Reader Documents](#).

Table 15: Impinj R700 User Documentation

Document	Description
Impinj R700 Quick Start Guide	Simple guide to begin using the Impinj R700
Impinj R700 Installation and Operations Guide	Detailed instructions for installing, connecting, configuring, operating, upgrading, and troubleshooting the Impinj R700
RShell Reference Manual	Guide to using the Reader Shell (RShell) command line interface to configure, maintain, and query the status of Impinj RAIN RFID readers
Impinj Octane LLRP Guide	Describes the LLRP capabilities supported by Impinj RAIN RFID readers, which includes Impinj custom LLRP extensions
Impinj R700 Embedded Development Quick Start Guide	Guide to begin developing custom on-reader applications
Impinj R700 Firmware Release Notes	Details up to date features and known issues

8 CHANGE LOG

8.1 June 2020

- Updated to include Impinj R700 ETSI reader model information
- Updated to reflect features of Impinj R700 firmware version 7.1
- Minor formatting changes

8.2 October 2020

- Updated to include Impinj R700 FGX reader model information
- Removed Impinj R700 FCC reader model information
- Updated to reflect features of Impinj R700 firmware version 7.3
- Minor formatting changes

8.3 February 2021

- Updated to include Impinj R700 Japan reader model information
- Updated Accessory table to include Impinj R700 antenna hub and Impinj R700 water-resistant case
- Updated to reflect features of Impinj R700 firmware version 7.4
- Updated specification table to indicate Impinj Speedway R120 End-of-Life status
- Minor formatting changes

8.4 July 2021

- Updated document to use new style format
- Updated Impinj fixed reader comparison table to reflect addition of Impinj R220 support for Impinj Speedway Antenna Hub
- Updated Regulatory Certification

9 NOTICES

Copyright © 2021, Impinj, Inc. All rights reserved.

Impinj gives no representation or warranty, express or implied, for accuracy or reliability of information in this document. Impinj reserves the right to change its products and services and this information at any time without notice.

EXCEPT AS PROVIDED IN IMPINJ'S TERMS AND CONDITIONS OF SALE (OR AS OTHERWISE AGREED IN A VALID WRITTEN INDIVIDUAL AGREEMENT WITH IMPINJ), IMPINJ ASSUMES NO LIABILITY WHATSOEVER AND IMPINJ DISCLAIMS ANY EXPRESS OR IMPLIED WARRANTY, RELATED TO SALE AND/OR USE OF IMPINJ PRODUCTS INCLUDING LIABILITY OR WARRANTIES RELATING TO FITNESS FOR A PARTICULAR PURPOSE, MERCHANTABILITY, OR INFRINGEMENT.

NO LICENSE, EXPRESS OR IMPLIED, BY ESTOPPEL OR OTHERWISE, TO ANY PATENT, COPYRIGHT, MASKWORK RIGHT, OR OTHER INTELLECTUAL PROPERTY RIGHT IS GRANTED BY THIS DOCUMENT.

Impinj assumes no liability for applications assistance or customer product design. Customers should provide adequate design and operating safeguards to minimize risks.

Impinj products are not designed, warranted or authorized for use in any product or application where a malfunction may reasonably be expected to cause personal injury or death, or property or environmental damage ("hazardous uses"), including but not limited to military applications; life-support systems; aircraft control, navigation or communication; air-traffic management; or in the design, construction, operation, or maintenance of a nuclear facility. Customers must indemnify Impinj against any damages arising out of the use of Impinj products in any hazardous uses.

Impinj, and Impinj products and features are trademarks or registered trademarks of Impinj, Inc. For a complete list of Impinj Trademarks, visit www.impinj.com/trademarks. All other product or service names may be trademarks of their respective companies.

The products referenced in this document may be covered by one or more U.S. patents. See www.impinj.com/patents for details.