



Datasheet

MATCHBOX ANTENNA

READER ANTENNA DATASHEET

TABLE OF CONTENTS

1	Overview	1
1.1	Features.....	1
2	Read Zone Characteristics	1
3	Specifications	2
3.1	Electrical Specifications.....	2
3.1.1	Magnetic Field Intensity Plots	3
3.2	Environmental Specifications	4
3.3	Mechanical Specifications	5
3.3.1	Mechanical Drawings	5
4	Ordering Information	6
5	Notices	6

1 OVERVIEW

The Impinj Matchbox antenna is a very small RAIN RFID antenna suited for embedded applications needing strong performance in a tight read zone. The MatchBox reader antenna is the ideal antenna for item level applications that require reading tags at distances up to 5 cm. Typical applications include loss prevention, portable readers, RAIN RFID printers, access control, ticketing, document control, high-speed encoding stations, packaging lines, and any situation that requires high reliability in a constrained read zone.

The MatchBox antenna, with its optimized near-field performance, is virtually immune to the effects of liquids, powders, packaging, etc. The MatchBox antenna works for applications where standard antennas may fail, such as membership cards, blister packs, pill bottles, liquid-filled containers, and even tags floating in water.

Figure 1: MatchBox Antenna Picture



1.1 Features

- Adaptable to situations that require high reliability with a constrained read zone from 0-5
- Compact installation for space-constrained areas, mounts easily into confined spaces
- Performs over a wide range of frequencies that can be used in multiple regions
- Small size: 7.3 x 3.3 x 1.1 cm

2 READ ZONE CHARACTERISTICS

The MatchBox antenna emits RF energy from both the top and bottom surfaces. Tags are essentially unreadable beyond 5 cm from the antenna surface

Figure 2: Read Zone Diagram

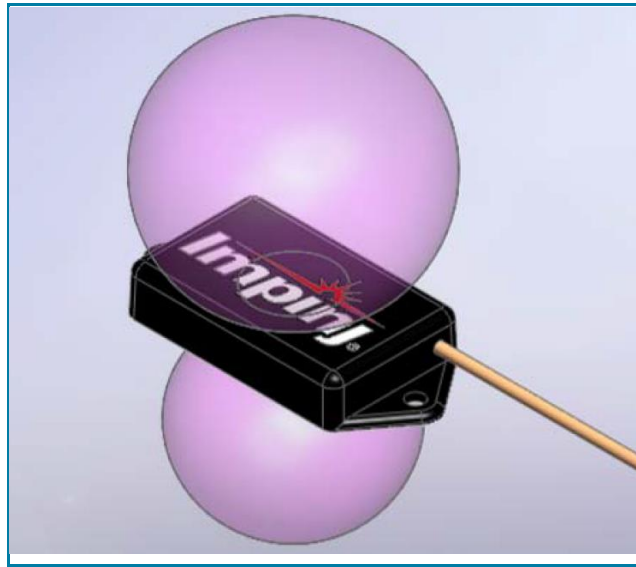

3 SPECIFICATIONS

3.1 Electrical Specifications

Table 1: Electrical Specifications

PARAMETER	VALUE
Frequency Range	865 to 956 MHz; broadband for use in all regions
Polarization	Linear (Parallel to Short Axis)
Far-Field Gain	-20 dBi
Near-Field Intensity	-4.2 dBA/m
VSWR Across Frequency Range	1.25:1 typical
Nominal Impedance	50 Ω
Input Power	30 dBm
Electrostatic Discharge	2 KV (Human Body Model)

3.1.1 Magnetic Field Intensity Plots

Figure 3: Magnetic Field Intensity Plot, X-Y Plane

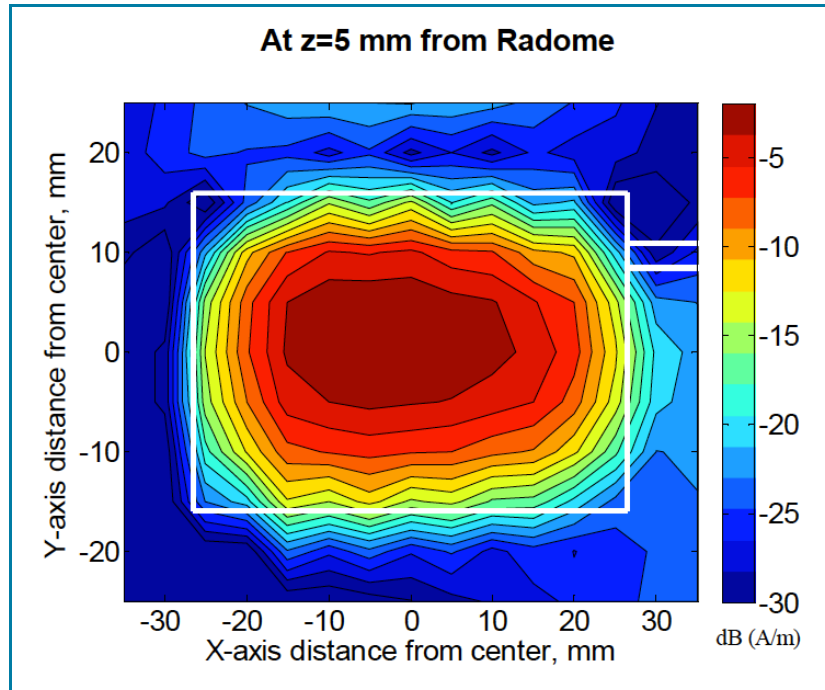

Figure 4: Magnetic Field Intensity Plot, X-Z Plane

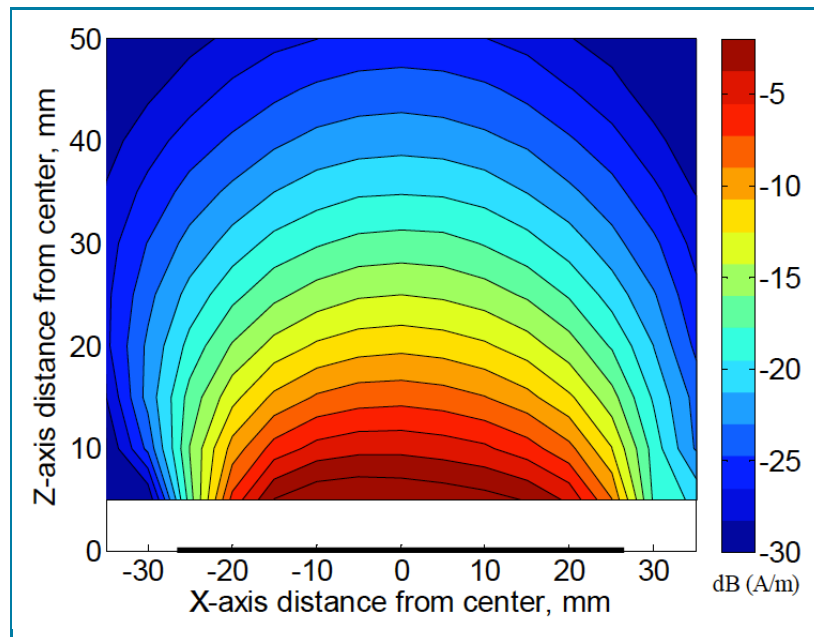
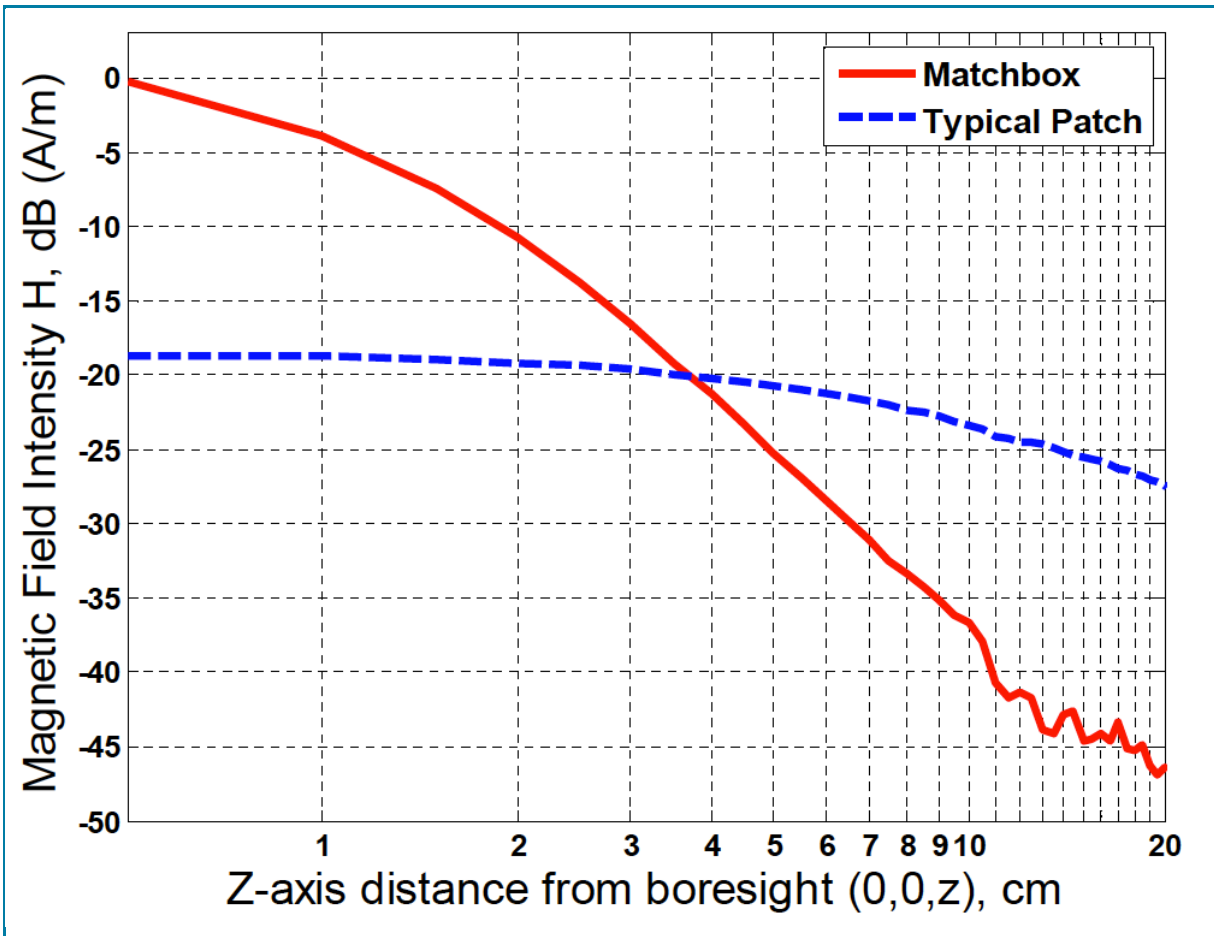

Figure 5: Magnetic Field Intensity vs. Typical Patch Antenna



Intensity measured in dB (Amperes/meter) with +30 dBm input power

3.2 Environmental Specifications

Table 2: Environmental Specifications

PARAMETER	VALUE
Environmental Rating	IP54 (Indoor Use Only)
Operating & Storage Temperature	0 °C – 40 °C (32 °F – 104 °F)
Humidity	5%-95% (Relative, Non-Condensing)

3.3 Mechanical Specifications

Table 3: Mechanical Specifications

PARAMETER	VALUE
Dimensions (L x W x D)	2.9 x 1.3 x 0.47 in (with 8 in pigtail)
	7.3 x 3.3 x 1.1 cm (with 20 cm pigtail)
Weight	.04 lbs/.02 kgs
Mounting	2 holes, 4mm diameter spaced 62mm
RoHS	RoHS Compliant
Enclosure Material	BlackABS
Cable Length	20 cm
Connector Type	SMA female

3.3.1 Mechanical Drawings

Figure 6: MatchBox Antenna Enclosure

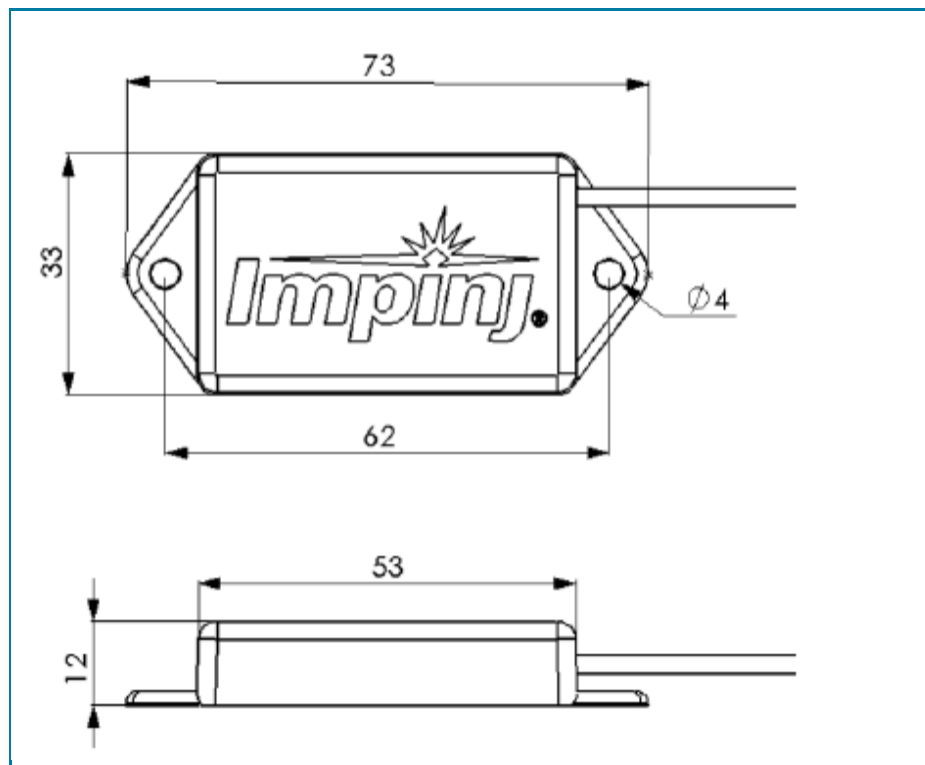

4 ORDERING INFORMATION

Table 4: Ordering Information

PART NUMBER	DESCRIPTION
IPJ-A0404-000	Impinj MatchBox Antenna

5 NOTICES

Copyright ©2018, Impinj, Inc. All rights reserved.

Impinj gives no representation or warranty, express or implied, for accuracy or reliability of information in this document. Impinj reserves the right to change its products and services and this information at any time without notice.

EXCEPT AS PROVIDED IN IMPINJ'S TERMS AND CONDITIONS OF SALE (OR AS OTHERWISE AGREED IN A VALID WRITTEN INDIVIDUAL AGREEMENT WITH IMPINJ), IMPINJ ASSUMES NO LIABILITY WHATSOEVER AND IMPINJ DISCLAIMS ANY EXPRESS OR IMPLIED WARRANTY, RELATED TO SALE AND/OR USE OF IMPINJ PRODUCTS INCLUDING LIABILITY OR WARRANTIES RELATING TO FITNESS FOR A PARTICULAR PURPOSE, MERCHANTABILITY, OR INFRINGEMENT.

NO LICENSE, EXPRESS OR IMPLIED, BY ESTOPPEL OR OTHERWISE, TO ANY PATENT, COPYRIGHT, MASKWORK RIGHT, OR OTHER INTELLECTUAL PROPERTY RIGHT IS GRANTED BY THIS DOCUMENT.

Impinj assumes no liability for applications assistance or customer product design. Customers should provide adequate design and operating safeguards to minimize risks.

Impinj products are not designed, warranted or authorized for use in any product or application where a malfunction may reasonably be expected to cause personal injury or death, or property or environmental damage ("hazardous uses"), including but not limited to military applications; life-support systems; aircraft control, navigation or communication; air-traffic management; or in the design, construction, operation, or maintenance of a nuclear facility. Customers must indemnify Impinj against any damages arising out of the use of Impinj products in any hazardous uses.

Impinj, and Impinj products and features are trademarks or registered trademarks of Impinj, Inc. For a complete list of Impinj Trademarks, visit www.impinj.com/trademarks. All other product or service names may be trademarks of their respective companies.

The products referenced in this document may be covered by one or more U.S. patents. See www.impinj.com/patents for details.